

Extension Neck Fitting Instructions

- Remove existing riser and lid assembly.
- Position Ext Neck onto shaft using existing gasket.
- Fit second Ext neck if required on top of first Ext neck using gasket supplied.
- Trim existing neck to required height if necessary.
- Reposition riser assembly on top of Ext neck using gasket supplied

DRAFT

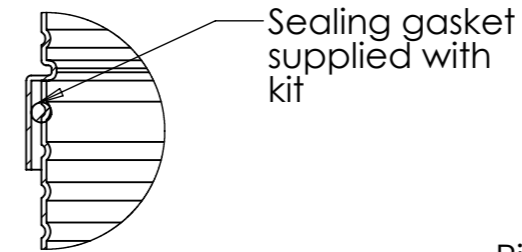

DETAIL C
SCALE 2 : 15

Riser assembly can be moved up and down to required invert.

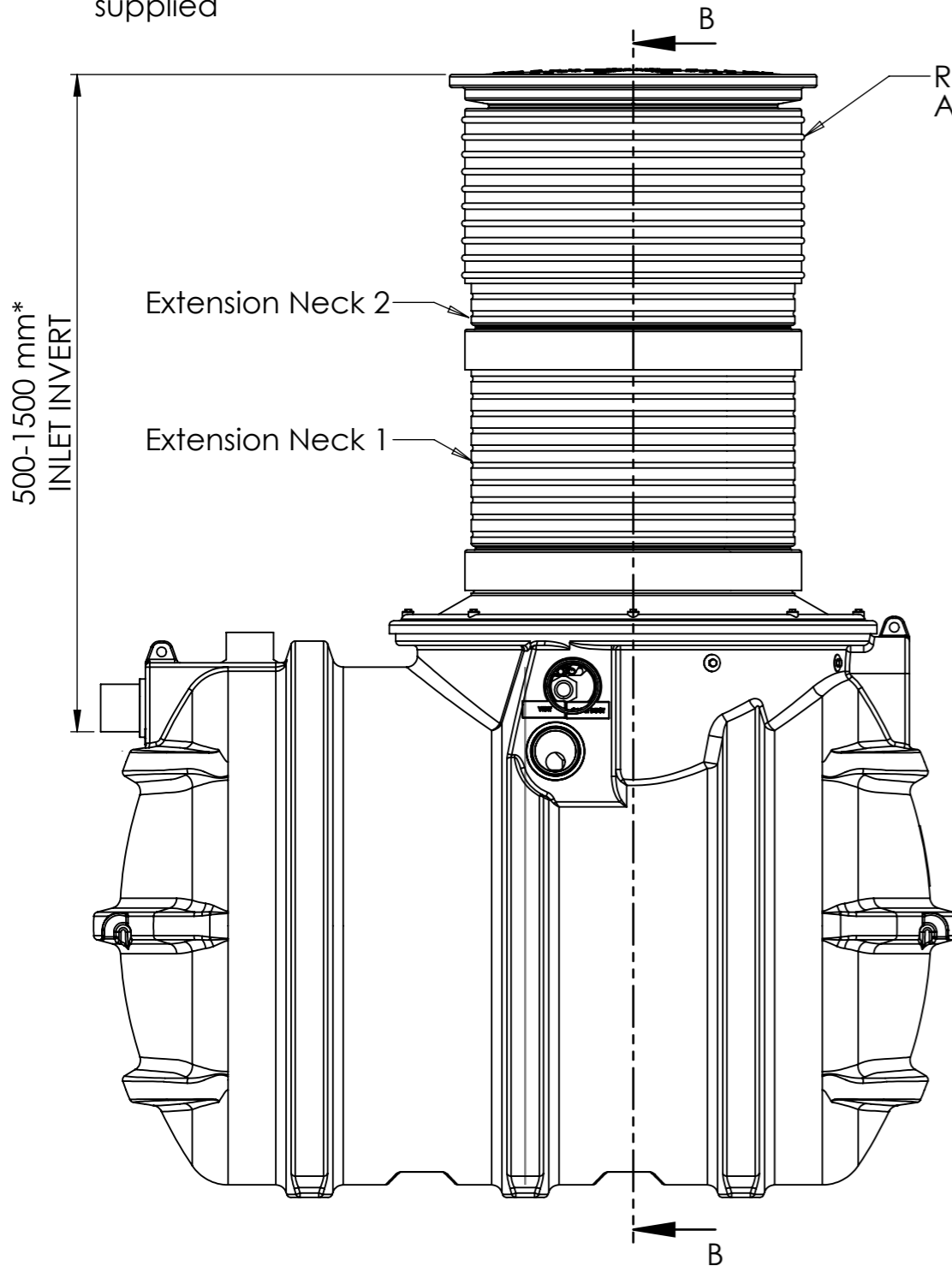
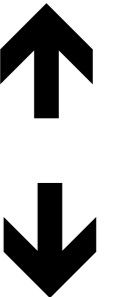

TWIN EXTENSION NECK ASSEMBLY

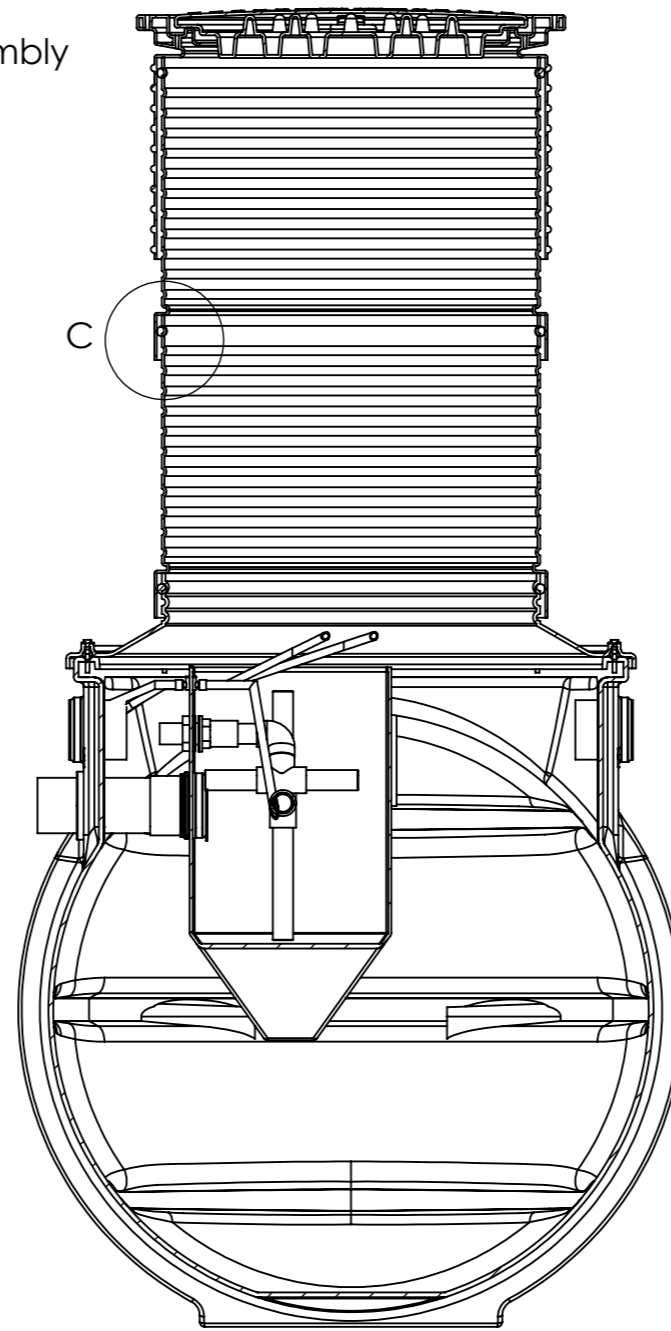

SECTION B-B
SCALE 1 : 15

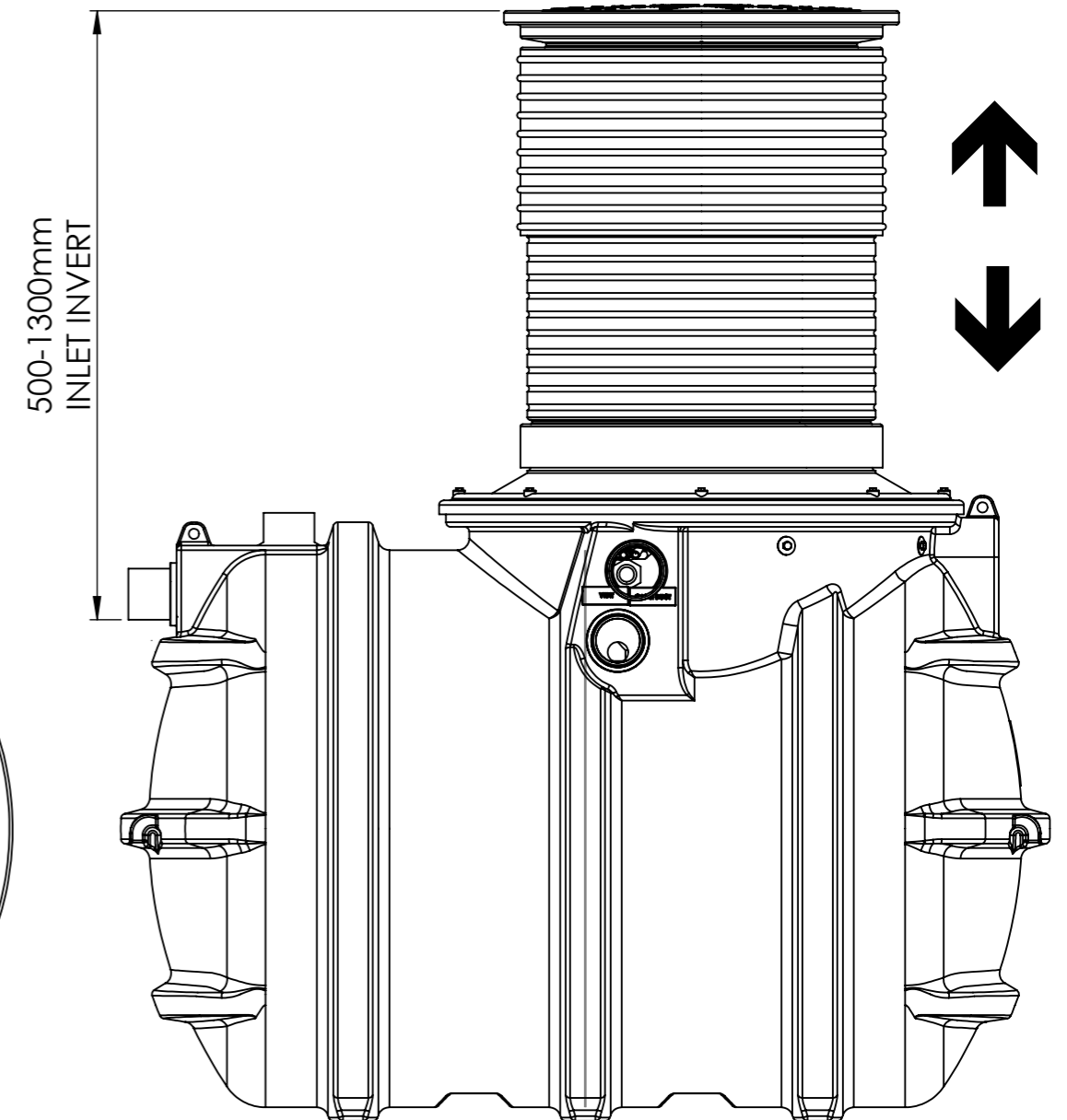

SINGLE EXTENSION NECK ASSEMBLY

*** A maximum Inlet invert depth of 1500 mm is recommended for this unit.**

Please check with Kingspan Environmental that this drawing is the latest issue				
Issue	Date	Drawn by	Approved by	Description
01	19/11/12	S.Gill		Initial Release

Material : PE
Finish :
Weight : Kgs

Tolerance :
Thickness :
Surface Area :

Drawing : DS1213 Page 1 of 1
BIOPURA 4 EXTENSION NECK ASSEMBLY

All dimensions in mm

Scale: Not to scale

Kingspan Environmental reserve the right to alter the details of this drawing without prior notice. This drawing is copyright and may not be reproduced or used without the written permission of Kingspan Environmental.

