

kod produktu / product code: 0600713

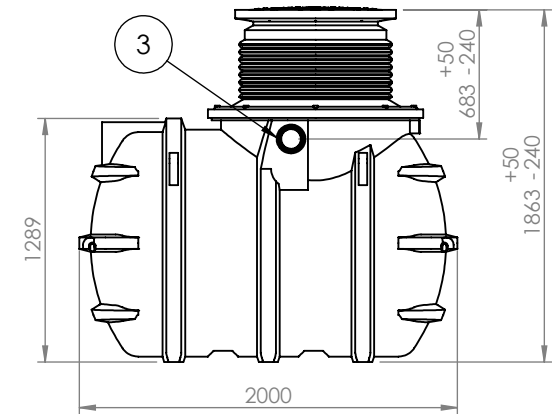
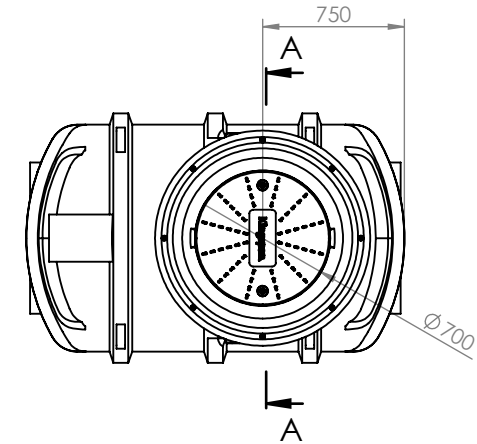
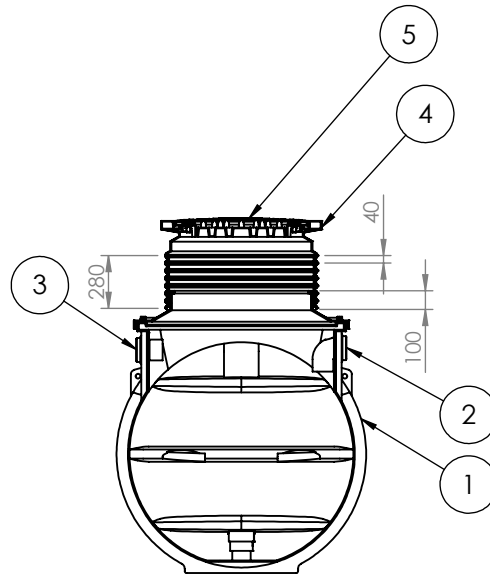
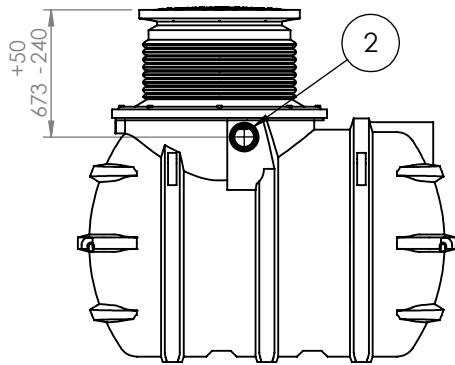
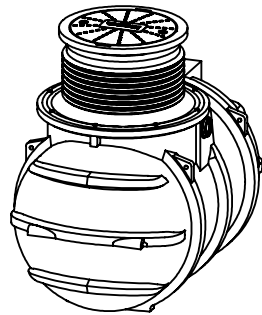

PRZEKRÓJ / SECTION A-A

Nr / No.	Opis / Description
1	zbiornik / tank
2	wlot / inlet
3	wylot / outlet
4	regulowany wąż / adjustable shaft
5	pokrywa / manhole cover

POP. REV.	OPIS DESCRIPTION	DATA DATE	ZATWIERDZIŁ APPROVED
A	określono zakres regulacji węża oraz przyłączy	15.03.2021	J. Kasprzak
B	zmieniono poj. nominalną zbiornika dodano kod produktu	17.09.2021	J. Kasprzak

material / material PE		wykończenie / finish		Kingspan Water & Energy Sp. z o.o., ul. Topolowa 5, 62-090 Rokietnica, Poland tel. +48 61 814 44 00, fax. +48 814 54 99 www.environmental.kingspan.com	
Rysunek i projekt są własnością firmy Kingspan Water & Energy Sp. z o.o.. Nie mogą one być KOPIOWANE, ROZPOWSZECHNIANE ORAZ REPRODUKOWANE W ŻADEN SPOSÓB bez pisemnej zgody. / The drawing and design are the property of Kingspan Water & Energy Sp. z o.o.. They may not be COPIED, RE-ISSUED or REPRODUCED IN ANY WAY without written permission.					
uwagi / remarks oczyszczyć i zatępić ostre krawędzie deburr and break sharp edges		tytuł / title Podziemny zbiornik na wodę deszczową Underground rainwater tank RainStore 1950 L		nr. rys. / dra. no. KE00_RAINSTORE_0004_1020	
masa / weight		skala / scale 1:40		rysował / drawn by Jakub KASPRZAK	
rozmiar ark./ format A4		arkusz / sheet 1/1		data / date 27.10.2020	
zaprojektował / designed by				zaprojektował / approved by	

