

CEMO CUBE

Stationary tank systems for diesel

Most fuel stations available today have been adapted from oil storage tanks and often give the appearance of being cobbled together as best as possible. Perhaps now is the time to redesign from scratch and produce a purpose- designed fuel station better suited to today's user.

CEMO present the latest in security, function and design in the CUBE. We have introduced features with benefits, not compromises and jigs. The first dispensing station to be designed as a dispensing station with everything in its place, easily accessible and straightforward to use. It's impressive – a great concept. Take a look and see if you agree.



Video CUBE-Tank



electric connection access integrated in lid

Cable duct allows easy connection to the electric pump.



ergonomic

All equipment is positioned so that it is easy to see and access at an optimum level over the bund.



always tidy

The automatic hose reel helps you keep 8 m of hose in order.

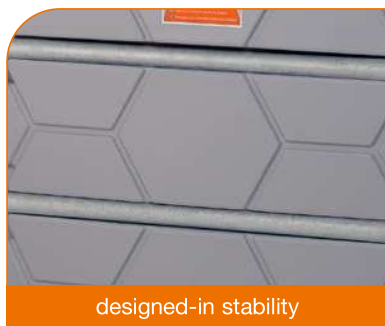

designed-in stability

The honeycomb structure (1,000, 1,500, 2,500, 5,000 L) and steel supports (1,000, 1,500, 2,500 L) result in superior robustness.



double protection

Integral 110 % bund gives added environmental protection.

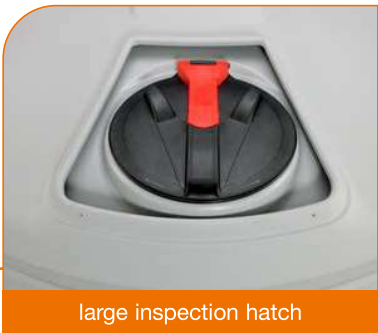

large inspection hatch
Hinged lid with 380 mm opening for tank inspection (5,000 L).

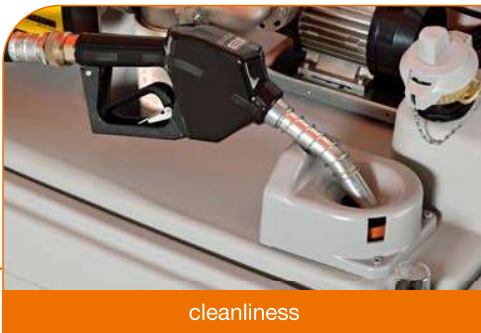

cleanliness
The integrated dispensing nozzle holder catches drops after filling.



CUBE diesel tank 5,000 L
Outdoor Premium



open on all sides
When open, the lid gives unimpeded access to all components from three sides.

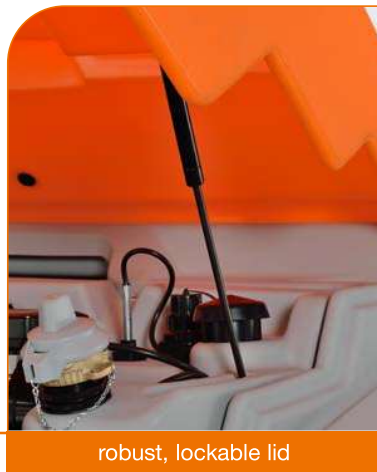

robust, lockable lid
Lockable lid secured by toggle latches. Opens upwards on supporting gas struts to allow access from three sides.



wind damage prevention
Four points for securing the tank to the ground to protect from strong wind damage (5,000 L version)



easy to lift
Three connection points on the circumference for shackles or lifting eyes when being lifted from above (5,000 L version)

CEMO CUBE

Stationary tank systems for diesel PG 4

Diesel

Diesel tank dispensing system, Basic and Premium

with general construction inspection approval no. Z-40.21-510

- comprising integrated bund
- visual bund alarm
- tanker coupling
- electronic overfill sensor
- vent
- analogue contents gauge
- suction hose
- 230 V pump 56 L/min (72 L/min on 2,500 L versions)
- 4 m delivery hose
- automatic nozzle with integral nozzle holder
- approved for outdoor installation with hinged lid (outdoor model)
- completely assembled



CUBE diesel tank 1,500 L Outdoor

CUBE diesel tank 2,500 L Indoor Basic

CEMO CUBE diesel tank 2,500 litre Outdoor Premium

- K33 meter
- filter with water separator
- hose reel with 8 m hose DN 19

Order no. 10299

TOP SELLER

CEMO CUBE diesel tank

Description	Capacity L	External dimensions cm (w x d x h)	Weight approx. kg	Order no.
Indoor Basic 4 m filling hose DN 19, without hinged lid	1000	120 x 80 x 174	135	10420
	1500	120 x 115 x 174	165	10292*
	2500	120 x 180 x 174	220	10293***
Outdoor Basic 4 m filling hose DN 19, with hinged lid	1000	120 x 80 x 180	150	10294*
	1500	120 x 115 x 180	180	10295*
	2500	120 x 180 x 180	235	10296***
Outdoor Premium K33 flow meter, cartridge filter with water separator, hose reel with 8 m hose DN 19, with hinged lid	1000	120 x 80 x 180	170	10297*
	1500	120 x 115 x 180	200	10298*
	2500	120 x 180 x 180	255	10299***
CUBE-Tank Extension I Indoor: CUBE-Tank with integrated bund, with visual bund alarm, filling connection with tanker coupling and overfill prevention sensor, vent, analogue contents gauge, suction hose with connection kit to first tank, completely assembled	1500	120 x 115 x 174	155	10776
CUBE-Tank Extension I Outdoor: same as CUBE-Tank Extension I Indoor, incl. with hinged lid	1500	120 x 115 x 180	170	10774
	2500	120 x 180 x 180	225	10300
CUBE-Tank Extension II Indoor: same as CUBE-Tank Extension I Indoor, only with connection to CUBE-Tank Extension II	1500	120 x 115 x 174	155	10777
	2500	120 x 180 x 174	210	10544
CUBE-Tank Extension II Outdoor: same as CUBE-Tank Extension II Indoor, incl. with hinged lid	1500	120 x 115 x 180	170	10775
	2500	120 x 180 x 180	225	10545

* with electric pump 56 L/min *** with electric pump 72 L/min (pump output in free flow. Please note that the pump output can fall sharply depending on the length and cross-sectional area of the hose.)

CEMO CUBE Outdoor PG 4

Premium Plus and Premium Plus SIM

with tank data management system "CMO 10" and "CMO 20 SIM"

Diesel

**Diesel tank dispensing system,
Outdoor Premium Plus 10**
with general construction inspection
approval no. Z-40.21-510

- comprising integrated bund
- visual bund alarm
- tanker coupling
- electronic overfill sensor
- vent
- analogue contents gauge
- suction hose
- pump 230 V
- meter with access control and tank data management system "CMO 10" for up to 250 users
- incl. 5 user keys and 1 master key
- hose reel with 8 m hose DN 19
- automatic nozzle with integral nozzle holder
- with hinged lid approved for outdoor installation
- completely assembled

Outdoor Premium Plus 20 SIM
features as for Outdoor Premium Plus 10,
and also:

- for up to 999 users
- access via PIN code
- mileage / operating hours input
- electronic contents gauge
- GPS function
- modem for tank data transmission



CUBE diesel tank 2,500 L Outdoor Premium Plus 20 SIM

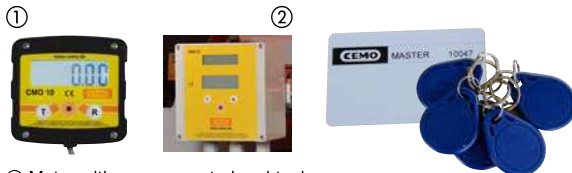

- ① Meter with access control and tank data management system "CMO 10" for up to 250 users
- ② Additional for Premium Plus 20 SIM: modem for tank data transfer, GPS function for up to 999 users

incl. 5 user and 1 master key



CUBE diesel tank Outdoor Premium Plus 10

Informations for the management system see page 19.

CEMO CUBE diesel tank

Description	Capacity L	External dimensions cm (w x d x h)	Weight approx. kg	Order no.
Outdoor Premium Plus 10	1000	120 x 80 x 180	170	10780*
	1500	120 x 115 x 180	200	10778*
	2500	120 x 180 x 180	255	10736***
Outdoor Premium Plus 20 SIM	1000	120 x 80 x 180	170	11320*
	1500	120 x 115 x 180	200	11321*
	2500	120 x 180 x 180	255	11322***

* with electric pump 56 L/min







*** with electric pump 72 L/min (pump output in free flow. Please note that the pump output can fall sharply depending on the length and cross-sectional area of the hose.)

CEMO CUBE

Stationary diesel tank systems PG 4

Diesel

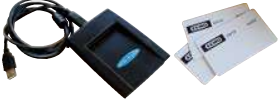
ACCESSORIES FOR CUBE DIESEL TANK 1,000, 1,500 AND 2,500 L

Description	Order no.
 <p>Hose reel with 8 m hose DN 19</p>	10375
 <p>K33 flow meter, 3-digit tank display</p>	10376
 <p>Filter with water separator</p>	10377
 <p>K33 meter, complete with filter and water separator</p>	10662
 <p>Meter with access control and "CMO 10" tank data management system for up to 250 users, incl. 5 user keys and 1 master key</p>	10745
 <p>Data transfer set with 3 data transfer cards and USB key reader for wireless data transfer to PC, incl. PC software</p>	10746
 <p>Key set with 5 user keys</p>	10747
 <p>LED instrument lighting with motion sensor and battery</p>	10378
<p>Hinged lid, orange, complete with supporting gas struts and mounting accessories</p>	10324

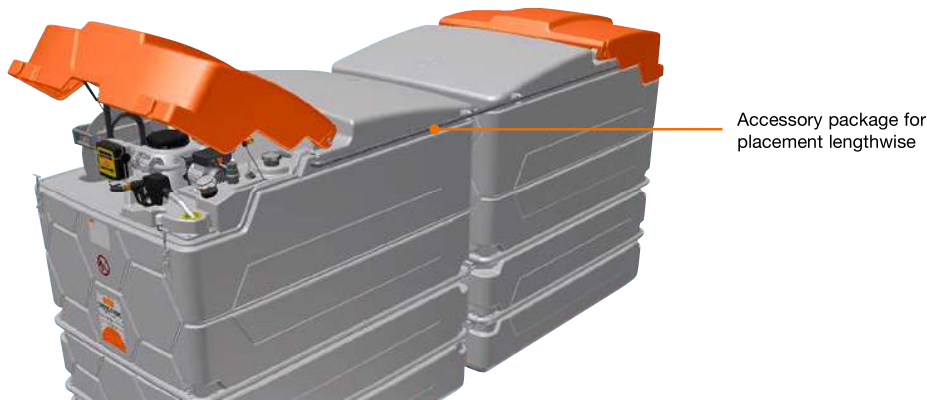

ACCESSORY FOR CUBE DIESEL TANK SYSTEM 5,000 L

Description	Order no.
<p>Accessory package for placement lengthwise in connection of two CUBE diesel tanks 2,500 L with expansion unit I (see page 14) or CUBE diesel filling stations 5000 L (see page 17)</p>	10666

CEMO CUBE diesel filling station PG 4

Diesel



CUBE diesel filling station, 5,000 L
Outdoor Premium



Filling the CUBE tank systems
is this easy.



Dispensing hose with connection to first tank and switching valves
included in the expansion kit.

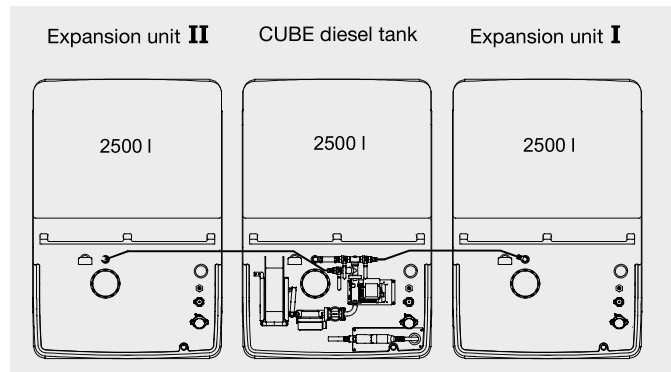

CUBE diesel filling station 7,500 L with expansion unit I and II

CEMO CUBE DIESEL TANK SYSTEM 5,000 L AND 7,500 L

Description	Comprising	Delivery rate L/min *	External dimensions cm (w x d x h)	Weight approx. kg	Order no.
5,000 L Indoor Basic	CUBE diesel filling station Indoor Basic (10293) and CUBE expansion unit I Indoor (10512)	72	250 x 180 x 174	430	10525
5,000 L Outdoor Premium	CUBE diesel filling station Outdoor Premium (10299) and CUBE expansion unit I Outdoor (10300)	72	250 x 180 x 180	480	10379
7,500 L Indoor Basic	CUBE diesel filling station Indoor Basic (10293), CUBE expansion unit I Indoor (10512) and CUBE expansion unit II Indoor (10544)	72	380 x 180 x 174	640	10546
7,500 L Outdoor Premium	CUBE diesel filling station Outdoor Premium (10299), CUBE expansion unit I Outdoor (10300) and CUBE expansion unit II Outdoor (10545)	72	380 x 180 x 180	705	10547

Accessories see page 16.

* Pump output in free flow. Please note that the pump output can fall sharply depending on the length and cross-sectional area of the hose.

CEMO CUBE diesel filling station 5,000 L PG 4

Diesel

Diesel tank dispensing system, Outdoor Basic and Outdoor Premium with general construction inspection Z-40.21-565

- with integrated bund
- with visual bund alarm
- filling connection with tanker coupling and overfill prevention sensor
- vent
- contents gauge
- suction hose
- pump 230 V, 72 l/min*
- automatic nozzle with integral nozzle holder
- with hinged lid approved for outdoor installation
- completely assembled



CUBE diesel tank 5,000 L, Outdoor Basic

CUBE diesel tank 5,000 L, Outdoor Premium

TOP SELLER

CUBE diesel tank 5,000 L Outdoor Premium

- capacity 5,000 litre
- pump 230 V
- K33 flow meter, filter with water separator, hose reel with 8 m hose, with hinged lid

Order no. 11079



CUBE DIESEL TANK 5,000 L

Description	Capacity L	External dimensions cm (w x d x h)	Weight approx. kg	Order no.
Outdoor Basic 4 m filling hose DN 25, with hinged lid	5,000	240 x 230 x 185	205	11078
Outdoor Premium K33 flow meter, cartridge filter with water separator, hose reel with 8 m hose DN 25, with hinged lid			230	11079
<u>CUBE-Tank Extension I Outdoor</u> CUBE-Tank with integrated bund, with visual bund alarm, filling connection with tanker coupling and overfill prevention sensor, vent, level gauge, suction hose with connection kit to first tank, completely assembled			201	11081
<u>CUBE-Tank Extension II Outdoor</u> same as CUBE-Tank Extension I Outdoor, only with connection to CUBE-Tank Extension II			201	11096

Accessories see page 20. * Pump output in free flow. Please note that the pump output can fall sharply depending on the length and cross-sectional area of the hose.

CEMO CUBE diesel tank 5,000 L Outdoor Premium Plus and Premium Plus SIM PG 4

with tank data management system "CMO20"

Diesel tank dispensing system, Outdoor Premium Plus 20 with general construction inspection approval no. Z-40.21-565

- with integrated bund
- with visual bund alarm
- filling connection with tanker coupling and overflow prevention sensor
- vent
- contents gauge
- suction hose

- pump 230 V/72 L/min*
- meter with access control and tank data management system „CMO20“ for up to 999 users, incl. 5 user keys and 1 master key
- hose reel with 8m hose DN 25
- automatic nozzle with integral nozzle holder
- with hinged lid approved for outdoor installation
- completely assembled

Outdoor Premium Plus 20 SIM*** same as Outdoor Premium Plus 20, additional with:

- electronic contents gauge
- GPS function
- modem for tank data transfer



CUBE Diesel tank 5,000 L, Outdoor Premium Plus 20 SIM



Meter with access control and tank data management system "CMO20" for up to 999 user

Additional for Premium Plus 20 SIM: modem for tank data transfer, GPS function

incl. 5 user and 1 master key

CUBE DIESEL TANK 5,000 L OUTDOOR PREMIUM PLUS AND PLUS SIM***

Description	Capacity L	External dimensions cm (wxdxh)	Weight approx. kg	Order no.
Outdoor Premium Plus 20	5000	240 x 230 x 185	212	11323
Outdoor Premium Plus 20 SIM***			212	11324

TANK SYSTEMS PREMIUM PLUS AND PLUS SIM*** WITH MANAGEMENT SYSTEM CMO10 AND CMO20

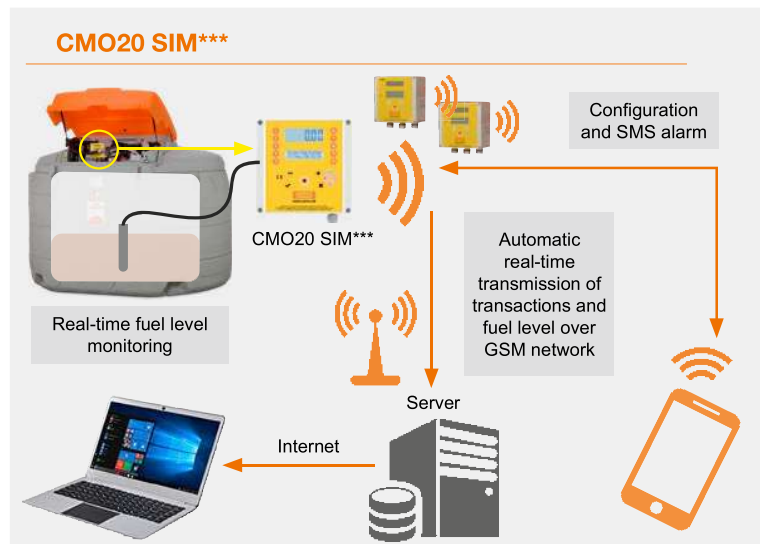









Accessories see page 20. * Pump output in free flow. Please note that the pump output can fall sharply depending on the length and cross-sectional area of the hose.

*** SIM card not included in the system.

CEMO CUBE diesel tank PG 4

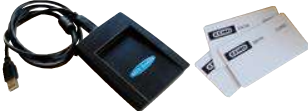
Diesel

ACCESSORIES FOR CUBE DIESEL TANK 5,000 L (SUPPLIED AS COMPONENTS)

Description	Order no.	
	Hose reel with 8 m hose DN 25	11092
	K33 flow meter, 3-digit tank display	10376
	Cartridge filter with water separator	11093
	K33 flow meter complete with Filter and water separator	11094
	Meter with access control and "CMO 10" tank data management system for up to 250 users, incl. 5 user keys and 1 master key	10745
	Data transfer set with 3 data transfer cards and USB key reader for wireless data transfer to PC, incl. PC software	10746
	Key set with 5 user keys	10747
	LED instrument lighting with motion sensor and battery	10378
	Hinged lid, orange, complete with supporting gas struts and mounting accessories	11095

CEMO CUBE diesel tank system PG 4

Diesel



CUBE diesel tank system 10,000 L Outdoor Premium



Suction hose with connection to first tank and switching valves included in the expansion unit.

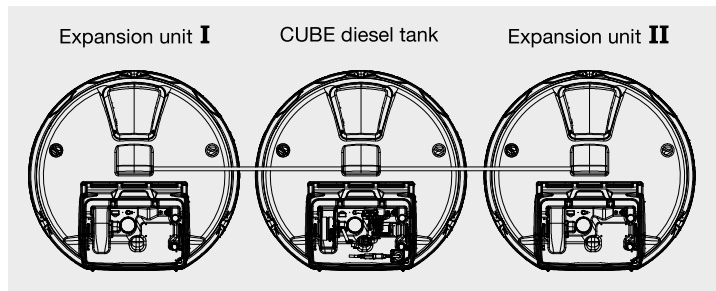

CUBE diesel filling station 15,000 L with expansion unit I and II

CUBE DIESEL TANK SYSTEM 10,000 L AND 15,000 L

Description	Comprising	Delivery rate L/min *	External dimensions cm (w x d x h)	Weight approx. kg	Order no.
10,000 L Outdoor Premium	CUBE diesel dispensing station Outdoor Premium (11079) and CUBE expansion unit I Outdoor (11081)	72	500 x 230 x 185	413	11097
15,000 L Outdoor Premium	CUBE diesel dispensing station Outdoor Premium (11079) and CUBE expansion unit I Outdoor (11081) and CUBE expansion unit II Outdoor (11096)	72	760 x 230 x 185	614	11098

Accessories see page 20.

* Pump output in free flow. Please note that the pump output can fall sharply depending on the length and cross-sectional area of the hose.