



FUEL MANAGEMENT SYSTEMS



DISPENSERS



KITS



PUMPS



METERS



NOZZLES

ST WITH METER AND FILTER

FEATURES

- **READY TO USE**
- **VERSATILE**
- **EASY TO INSTALL**
- **COMPACT DESIGN**
- **FILTRATION GUARANTEED**
- **AVAILABLE WITH DIFFERENT PUMPS**

PIUSI ST WITH METER AND FILTER is a range of dispensers particularly suited for all applications in which a filtration is required. The stations integrate PIUSI CLEAR or WATER CAPTOR FILTERS and are available with mechanical meter K33 or electronic meter K24/K600 B/3. They come with integrated check valve and 4-meter delivery hose.

PERFORMANCE

UP TO 90 L/MIN	AC CONTINUOUS DUTY
FLOW RATE	POWER
± 1%	UP TO 6MT LENGTH
ACCURACY	DELIVERY HOSE



ST PANTHER 56, K33, A60 E WATER CAPTOR



ST PANTHER 56, K33, A60 E CLEAR CAPTOR



ST PANTHER 56, K33, A60 AND WATER CAPTOR

ST PANTHER 72 BIO, K33 BIO, A70 BIO AND FILTER BIODIESEL

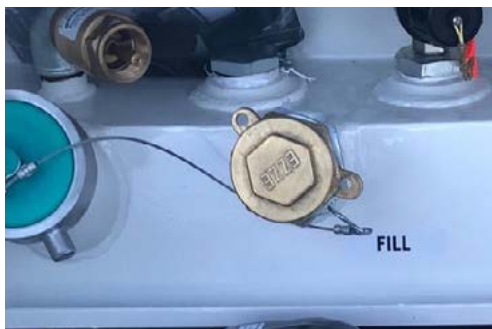

ST PANTHER 56, K33, A60 AND CLEAR CAPTOR



PACKAGING

CODE	WEIGHT		PACKAGING		
	KG	LBS	MM	INCH	PCS/BOX
FO0386FOA	25	55	580X380X320	22,8X15X12,6	1
FO0265FOA	26	57	580X380X320	22,8X15X12,6	1
FO0395FOA	32	71	545X435X340	21,5X17,1X13,4	1
FO0386F60	22	48	380X380X480	15X15X18,9	1
FO0386R70	22	48	380X380X480	15X15X18,9	1
FO0265F40	26	57	580X380X320	22,8X15X12,6	1
FO0265S80	26	57	580X380X320	22,8X15X12,6	1
FO0395F60	32	71	545X435X340	21,5X17,1X13,4	1
FO0265S20	18	40	480X370X260	18,9X14,6X10,2	1
FO0265R70	18	40	480X370X260	18,9X14,6X10,2	1
FO0395B00	29	63	560X450X370	22X17X14,5	1
FO0265B00	21	46	580X400X340	22,8X15,7X13,3	1



FILTRATION



TANK MONITORING



HOSE REEL



ACCESSORIES



MERCHANDISE



ANY BIODIESEL



AIR



ANTIFREEZE



AdBlue®



BIODIESEL



DIESEL



FOOD



GASOLINE



GREASE



KEROSENE



OIL



WATER



WINDSCREEN

AVAILABLE WITH DIFFERENT PUMPS AND METERS



AC PUMP - PANTHER 56/72



AC PUMP - E120



AUTOMATIC NOZZLE



MECHANICAL METER - K33



ELECTRONIC METER - K24



K600 B/3

DIMENSIONS

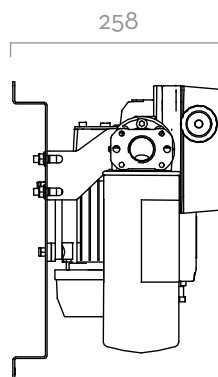
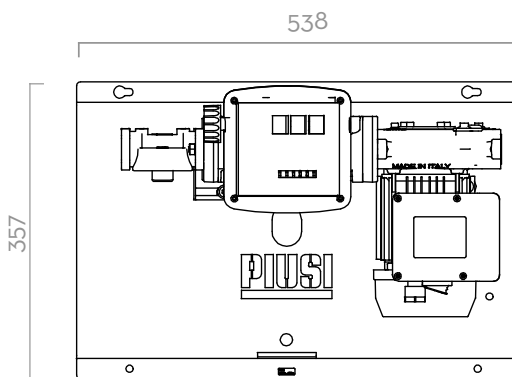

Dimensions expressed in millimeters

IN THE BOX

- ST WITH METER AND FILTER
- METER
- FILTER
- DELIVERY HOSE
- NOZZLE
- NOZZLE HOLDER
- INSTRUCTION MANUAL

DETAILS



WATER CAPTOR FILTER



MAN. / AUTOM. NOZZLE



K24 / K600 B/3 METER



K33 METER

COMPONENTS

- PUMPS:
PANTHER AC PAG. 100
E80/E120 PAG. 104
- NOZZLE:
AUTOMATIC NOZZLE PAG. 160
- METER:
K33 PAG. 148
K24 PAG. 134
K600 B/3 PAG. 138
- FILTER
WATER CAPTOR PAG. 172

TECHNICAL DATA

CODE	DESCRIPTION	FLUIDS TYPE	FLOW RATE		VOLTAGE			METER	NOZZLE	FILTER	DELIVERY HOSE		SUCTION HOSE		INLET
			L/MIN	GPM	AC V/ HZ	POWER. WATT	AMP. MAX.				LENGHT	Ø	LENGHT	BSP	
FOO386FOA	ST PANTHER 56 FILTER + A60	D	52	14	230/50	350	3	K33	A60	YES	6M	3/4"	4M	1"	-
FOO265FOA	ST PANTHER 72 FILTER + A60	D	70	18	230/50	500	4,2	K33	A60	YES	6M	3/4"	4M	1"	-
FOO395FOA	ST E120 FILTER + A120	D	85	22	230/50	1150	5,7	K33	A120	YES	6M	1"	4M	1"	-
FOO386F60	ST PANTHER 56 FILTER + A60	D	52	14	230/50	350	3	K33	A60	YES	6M	3/4"	-	-	-
FOO386R70	ST PANTHER 56 + CLEAR CAPTOR + A60	D	52	14	230/50	350	3	K33	A60	YES	6M	3/4"	-	-	-
FOO265F40	ST PANTHER 72 FILTER + A60	D	70	18	230/50	500	4,2	K33	A60	YES	6M	3/4"	-	-	-
FOO265S80	ST PANTHER 72 K600 B/F/6T/PA60	D	70	18	230/50	500	4,2	K600 B/3	A60	YES	6M	1"	-	-	-
FOO395F60	ST E 120 FILTER + A120	D	85	22	230/50	1150	5,7	K33	A120	YES	6M	1"	-	-	-
FOO265S20	ST PANTHER 72 FILTER + K24 METER	D	70	18	230/50	500	4,2	K24	A80	YES	6M	3/4"	-	-	-
FOO265R70	ST PANTHER 72 + CLEAR CAPTOR + A80	D	70	18	230/50	500	4,2	K24	A80	YES	6M	1"	-	-	-
FOO395B00	ST E120 K150/F/6MT/PA120 B100	BIO D	85	22	230/50	1150	5,7	K150 BIO	A120 BIO	NO	6M	1"	-	-	-
FOO265B00	ST PANTHER 72 K33/F/6MT/PA70 B100	BIO D	70	18	230/50	500	4,2	K33 BIO	A70 BIO	NO	6M	3,4"	-	-	-

ST WITH METER AND FILTER